

REVISION RECORD		
REV	DESCRIPTION	DATE
A/0		2007/08/10
A/1	Update edition	2009/12/19

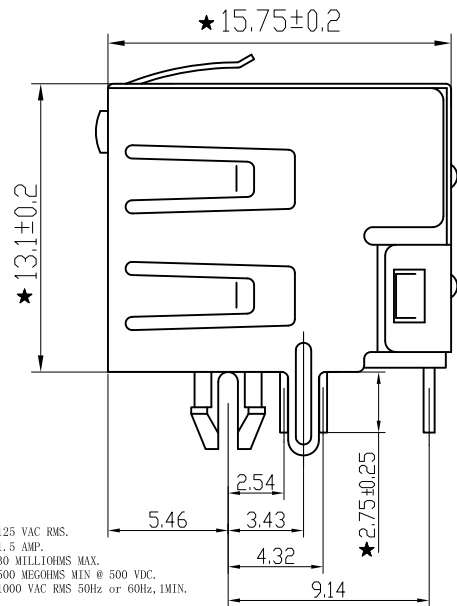
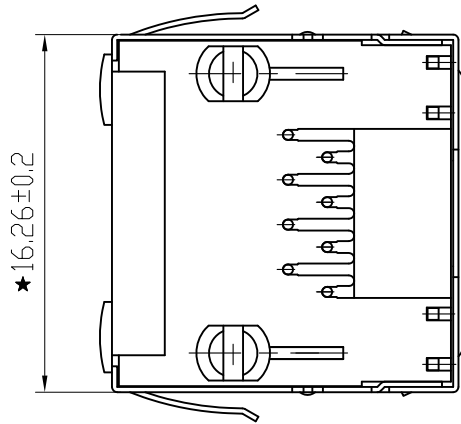

NOTES:

ELECTRICAL:

- VOLTAGE RATING : 125 VAC RMS.
- CURRENT RATING : 1.5 AMP.
- CONTACT RESISTANCE : 30 MILLIOHMS MAX.
- INSULATION RESISTANCE : 500 MEGOHMS MIN @ 500 VDC.
- DIELECTRIC STRENGTH : 1000 VAC RMS 50Hz or 60Hz, 1MIN.

MECHANICAL:

- HOUSING & INSERT MATERIAL : PBT UL94V-0.
- CONTACT MATERIAL : DIAMETER 0.45MM PHOSPHOR BRONZE GOLD PLATING OVER NICKEL.
- SHIELD : 0.20 ~ 0.25MM THICKNESS BRASS WITH TIN PLATED.
- MATING/UNMATING FORCE : 2.2KG. F MAX.
- RETENTION STRENGTH : 7.7KG. F MIN BETWEEN JACK AND PLUG.
- OPERATING LIFE : 600 CYCLES MIN.

ENVIRONMENTAL:

- STORAGE : -10°C ~ +40°C RELATIVE HUMIDITY<70%.
- OPERATION : -40°C ~ +70°C.

Remark:

- Tolerances Unless Otherwise Specified
.0±0.25 .00±0.20 .000±0.10
- The mark with ★ is the key inspection dimension for QC

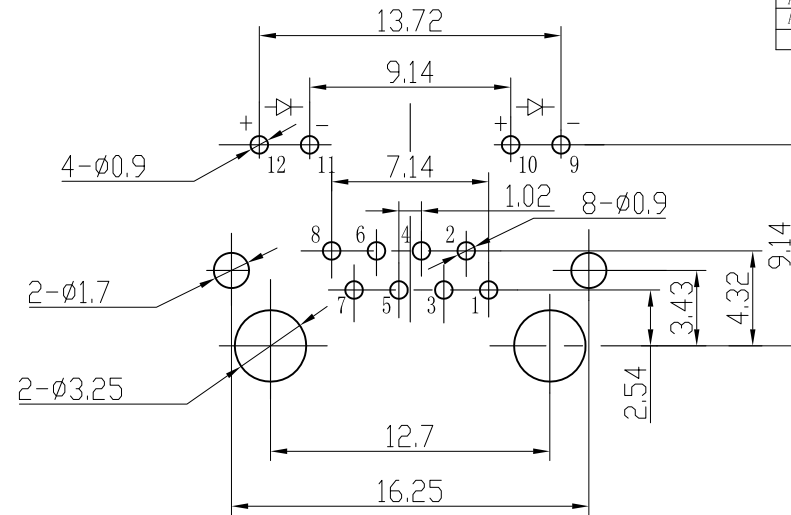

PC Board Layout

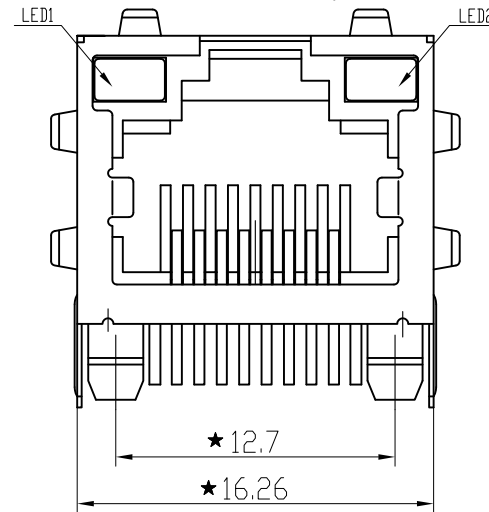

TELL	0769-81585156	www.coorle.cn		© 库乐科技		
Fax	0769-81605156					
Units	MM	Drawing		Material		Name
Scale	1 : 1	Check		SHIELD	H65Y	56S-LED 1X1-EMI
Rev'	A / 1	Approval		HOUSING	PBT	Part Number
View		Date	2008/06/05	PIN	Qsn6.5-0.1	File Name